



Certified Partner

ALLAN SMITH ENGINEERING PVT. LTD.

GLOBAL STANDARD OF SERVICE at local price



OUR JOB LIST: AS ON 2025

A. Details of job carried out on: Kiln / Calciner / Cooler / Dryer - Steel / Chemical / Cement / Fertilizers

SRNO	SERVICES RENDERED	NOS.
1	Alignments (two pier supported equipment's)	198
2	Hot Kiln Alignment (Three or more pier kiln)Kiln Predictive Analytic	96
3	Kiln Shell Profile Analysis (Advance)Segregation of Thermal and permanent Bend	07
4	Cold Alignment (three pier supported)	35
5	Leveling of machine (two pier supported equipment's)	17
6	Alignment of Girth Gear	48
7	Chair pad installation	34
8	Design	
	a. Full Floating chair pad....	16
	b. Thrust Roller	03
	c. Taper / Straight Shim.....	15
9	Chair pad shim calculation and installation	40
10	Solving frequent support roller bearing problem	
	a. Anti-friction bearing	30
	b. Journal bearing (HOT BEARING)	50
11	Solving thrust roller breaking problem	14
12	Solving high kiln amperage problem	27
13	Pinion base adjustment (during pre-commissioning check)	07
14	Crack tire repairs	11
15	Crack Girth gear repair	08
16	Supervision of base frames and support rollers erection	22
17	Kiln shell replacement (up to 3 sections at a time)	10
18	Girth gear replacement (Modified "Y" shape tension spring and Stool mounted)	15
19	Kiln seal fixing (outward lamella seal, Pneumatic slip seal)	10
20	Tyre replacement	22
21	Cooling cowl alignment	05
22	Supervision of complete kiln shell erection (42/65 meter long)	07
23	Blue matching of bush bearing	33
24	Support roller replacement	25
25	Support roller repair (weld repair and grinding)	07
26	Tyre / Support Roller / Thrust Face Grinding/ Slide Ring	75
27	Modification of cement kiln Tyre (fixed Tyre) fixing arrangement	03
28	Shifting of Tyre by 240.5 mm and installation of full welded chair pad	07
29	Base frame installation (in tight location)	05
30	Drum Installation in very tight location	06
31	Training	04

ABOUT US

Allan Smith Engineering Pvt. Ltd. is a reputed name in Rotary Kiln Industries for providing reliable engineering solutions. We offer customized and specialized maintenance services for recurring problem observed on kiln and components. The solution includes, Kiln Audit (carried out during normal operation), Kiln Alignment (**Hot and Cold**), diagnostic maintenance, and assistance in repairs (with surgical precision) on rotary Kiln. We are driven by excellence and aim to emerge as a principal name in the service provider industry. Our mission is to set new benchmarks in industry through our high quality services, well-designed and customized solutions. Our company is renowned for its expertise in troubleshooting typical and recurring problems, thus ensuring complete and reliable operations.

In order to provide high quality and best services, at par with international standard, we are being supported by "EUROKILN", an organization based in Europe. The European office also acts as knowledge centre and engaged in development of new instruments, procedure to provide better service to clients. Our engineering services are designed in reference to current industry trends and developments. We have earned trust of our clients, globally, by delivering desired services through our professional attitude and ethical business policies.

We are located in city of Mumbai, a business centre of India. **Allan Smith Engineering** commenced operation in 2009 and incorporated in 2011 under leadership of Mr. Laxmi Narayan. **Mr. Laxmi Narayan**, owner of the company has been presented with the National Award (India) for Innovations applied to plant maintenance, by Govt. of India.

Our Specialty

Our core competency is in designing of effective engineering solutions. We focus on troubleshooting and rectification of recurring problems observed on the machine, thus ensure reliable machine operation. Our team are well-versed with all make of machines and offer customised and reliable services

Team

We believe, our competent and resourceful team is an asset of our organization. Our team comprises of qualified and experienced mechanical engineers, supervisors, technicians and quality management personnel to mention a few. The team is working **cohesively** and **single minded**, dedicated towards the customer satisfaction

Customer Satisfaction

Customer Satisfaction is a major yardstick with which we evaluate our company's performance and growth (instead of INR turnover) We take every effort to exceed expectations of our customers. We designs and plan our services after considering the requirements and specifications put forward by the customer.

Our Services:

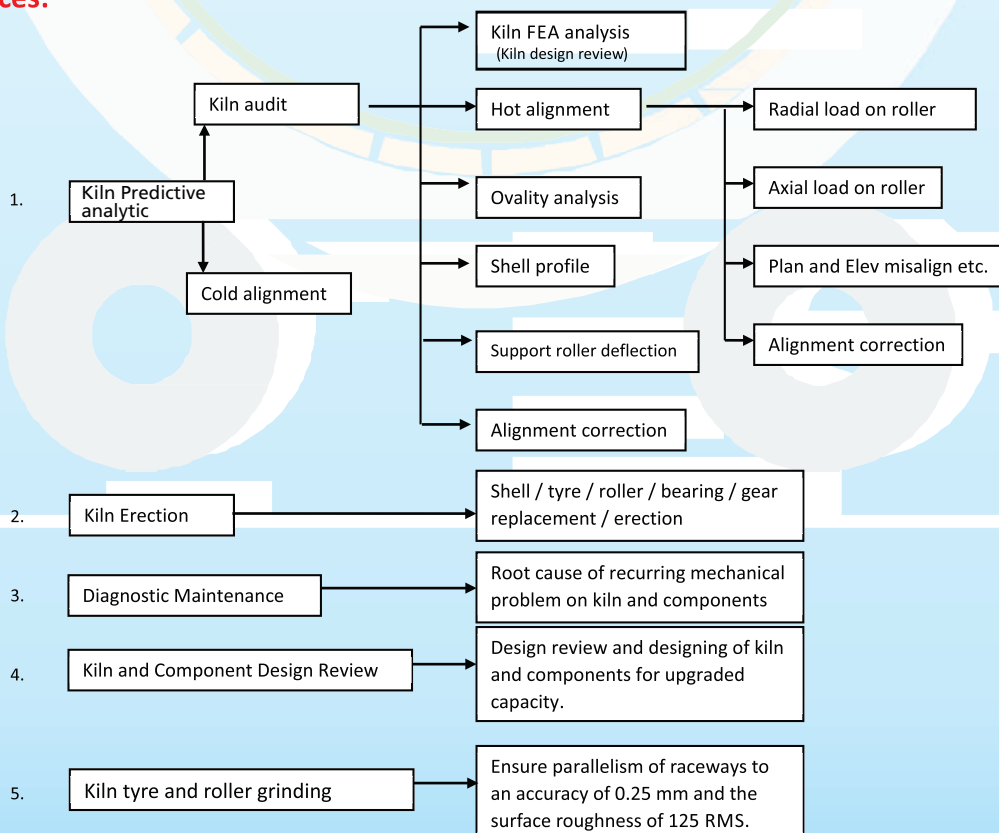

KILN AND COMPONENTS F.E.A. ANALYSIS

F.E.A. Analysis(Kiln and Components):

Now a day's Finite Element Analysis is being used to analyze failure analysis. FEA finds extensive application of FEA is in aerospace, automotive industry as well. In FEA, exact virtual model of machine element has been tested under practical conditions. Depending upon the test results, machine element can modify for its best performance in practice. We use FEA to carry out design review of kiln and components under normal operation. The Review and corrections ensures reliable and dependable operation.

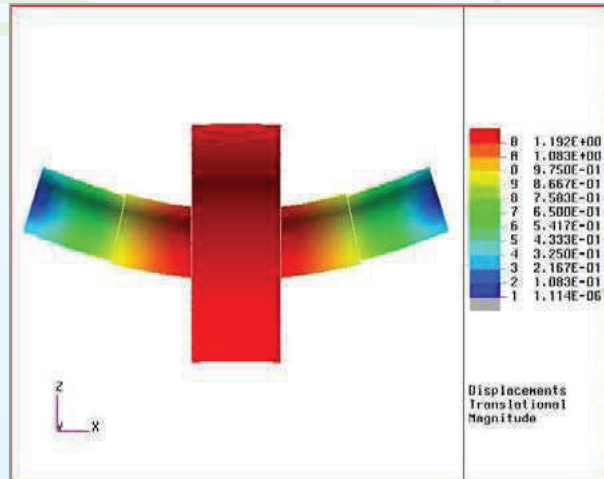

Air gap
Air gap

Recently we had carried out F.E.A. analysis to establish root cause of cement kiln support roller shaft shearing.

Typical bending stress and bending moment diagram drawn for KILN audit.

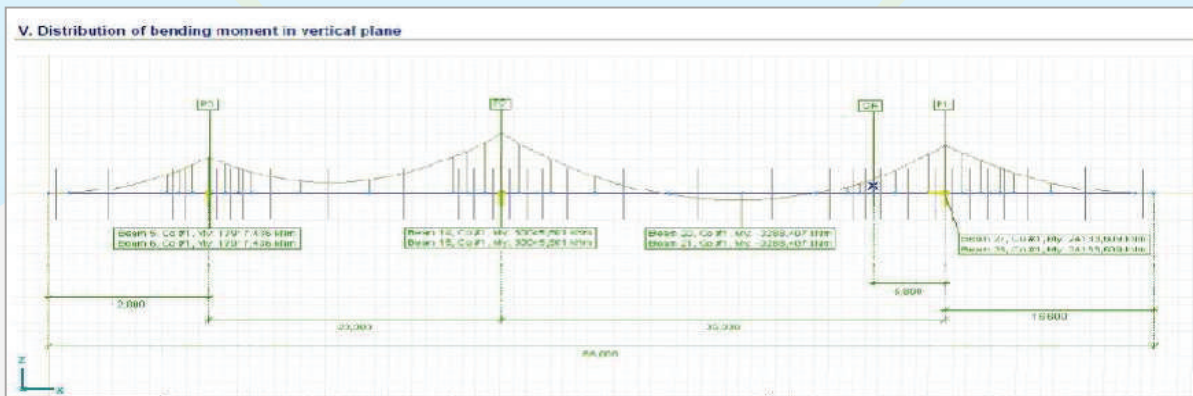

Kiln Shell Analysis:

Kiln shell bend predominantly affect kiln operation, mechanically and usually result in high variation of current drawn by the main motor. The bent also influence in bearing temperatures, tyre roller contact, girth gear pinion contact etc.

Air gap

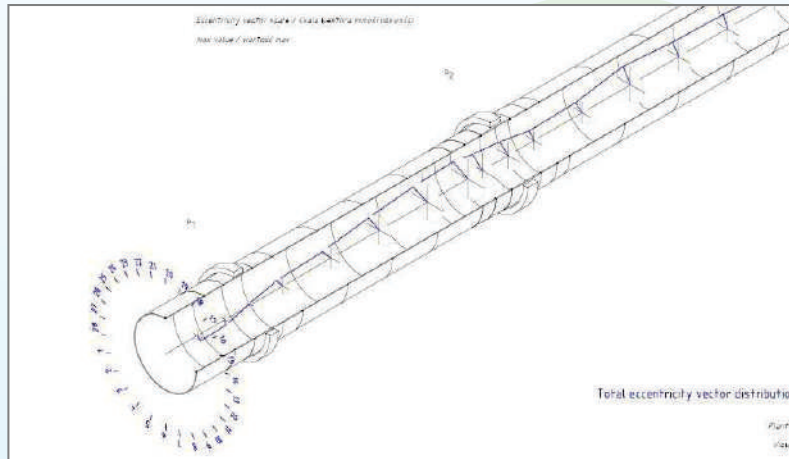

Determination of Kiln Shell Profile concluded upon the measurement using laser in complete shell length @ 2-3 meter span. And, conclusion drawn of shape of the kiln shell includes bent, hidden bent, dog leg situation in the shell. The data analyzed and presents as polar diagram for eccentricity and local deformations.

Additionally, we take reference of roller shaft deflection to conclude hidden cranks of the shell at support roller position. Also, we reverse calculate the shell bent causing shaft deflection and consider this in the real final shell axis shape.

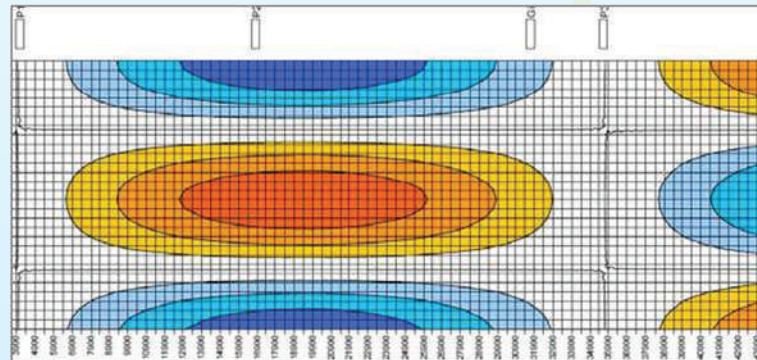

Polar and liner graph of kiln shell drawn using LASER data, collected at a position

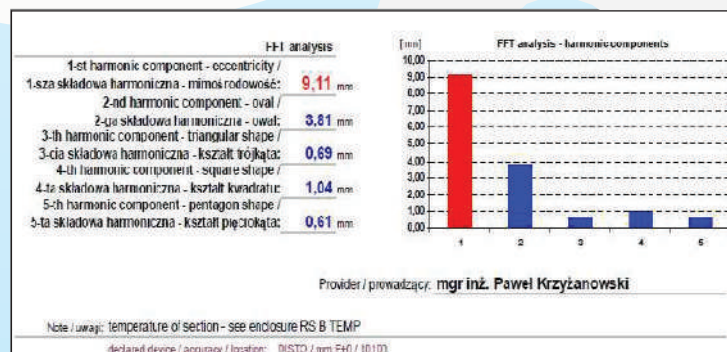
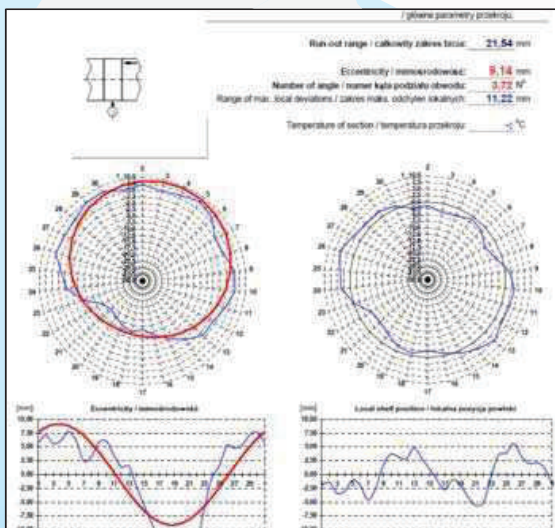

FFT analysis carried out of the above collected data.

SUPPORT ROLLER DEFLECTION

Support roller deflection

We carry out support roller deflection measurement, a dynamic deflection during normal Kiln operation. Data recorded for complete rotation of kiln using high precision digital dial gauge with an accuracy of 0.001mm. The deflection indicate **“hidden bend in kiln shell”**, support roller shaft strength under operation load, etc.

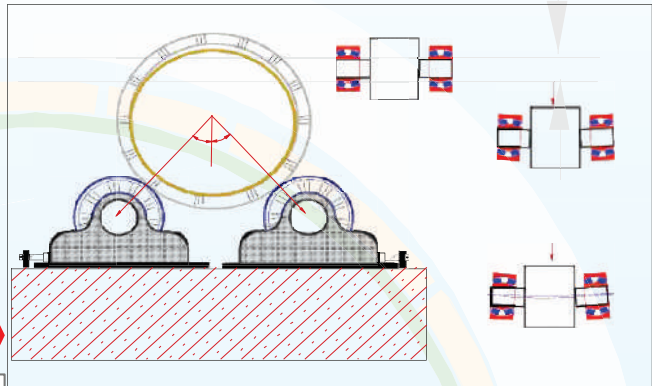

Air gap

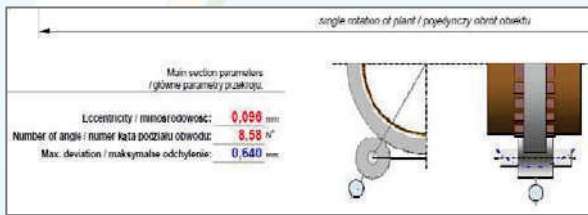

Kiln shell runout / eccentricity and hidden crank induce cyclical shaft deflection and leads to incipient of fatigue crack in the shaft.

Static deflection of the shaft will be higher but this we can't measure; we can measure only variation in the deflection during operation. The static deflection can only be measured during shutdown.

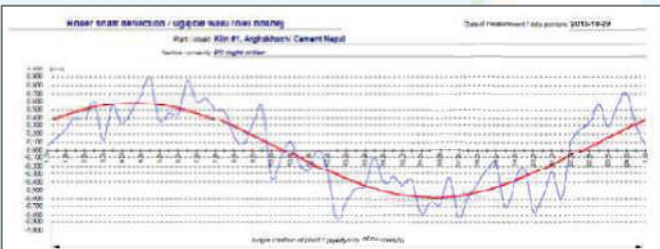

The value of dynamic deflection of support rollers is determined in reference to designed support roller dimensions. The data then compare to the measured value to conclude existence of any discrepancy.

HOT KILN ALIGNMENT

Hot Kiln Alignment (Optimization of kiln axis):

Kiln alignment is undertaken to ensure parallelism of center axis of kiln and all the support rollers. Measurements are carried out on kiln and support rollers to locate the existing axis. Depending

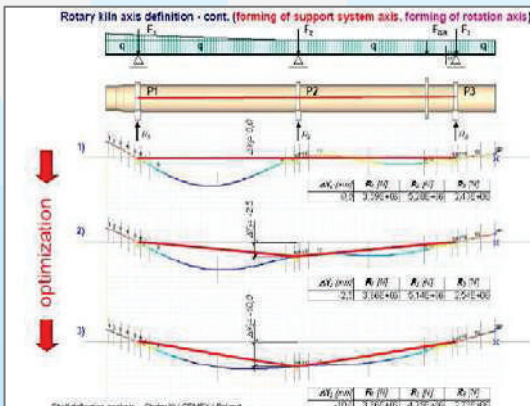

upon analyzed result, correction can be taken up to ensure parallelism in plan and elevation view.

Kiln misalignment influences on load distribution on the rollers. Possibility of load variation exists because of some or other reason like one roller has higher diameter than another Roller, rollers with different elevation difference etc. Optimization of kiln load on the rollers helps to reduce differential loading between rollers at same pier.

Problem like hot bearings, overturning of bearings, excessive wear on support rollers, and excessive wear on thrust rollers can be eliminated. Proper kiln alignment ensures proper load sharing on the support rollers.

Added features:

- As a standard procedure, we are carrying out FEA analysis to check the kiln stiffness. The stiffness helps to conclude the kiln is “stiff” or “flexible”.
- We evaluate local slopes of each tire (as shown below) - USP
- We optimize loading on the piers, depends upon stresses in the shell. Unique accuracy of our measurements is related to the possibility of access the support roller shaft end during operation.
- Our precision of the measurement is upto tens of millimeter. What we can see during rollers adjustment when moving the roller of 0’2 or 0’3 mm we are shifting for thrust direction

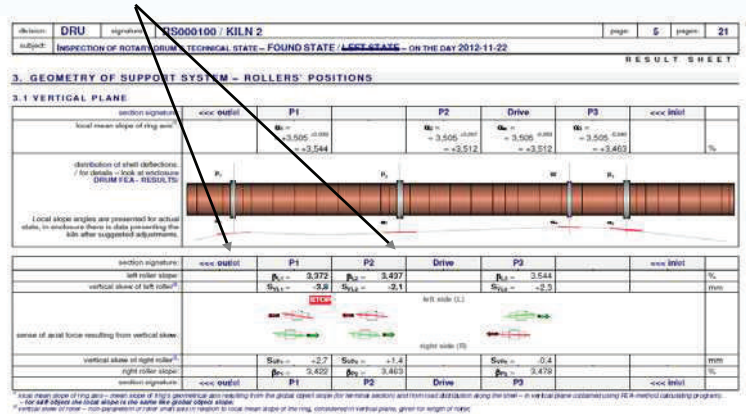

HOT KILN ADJUSTMENTS

Hot Kiln Adjustments:

We will be supervising the Hot Kiln Adjustments for the kiln alignment and skew adjustments, immediately after light up. We will ensure normal kiln floatation, If possible. Kiln will be moving uphill with required gauge pressure (on hydraulic thrust roller) of around 40 bars (or as recommended by OEM) and return to its position at downhill when applied hydraulic pressure is reduced.

MECHANICAL BALANCING OF KILN

We had an expertise to measure precisely support skewing of support roller, axial thrust in elevation as well in plain view. The measurement is concluded in “mm” and “ton” and accordingly the correction carried out to optimize the axial loading on the support roller. Kiln excessive travel may consequence in:

- Damaging thrust roller/ thrust face of thrust tire.
- Partly damaging kiln end seals because of excessive axial load on faceplates.
- Result in hot bearings / damaging of bearings of support rollers.
- Excessive wear and tear on the support roller and tires surfaces.

Optimum balancing of kiln axial load may help to reduce / eliminate the above mentioned problems.

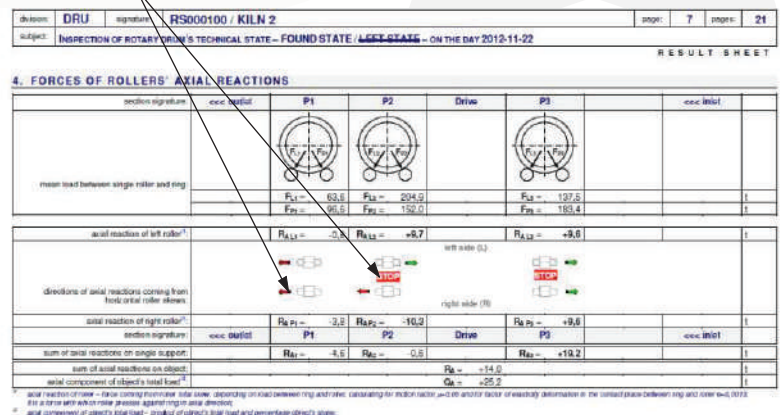
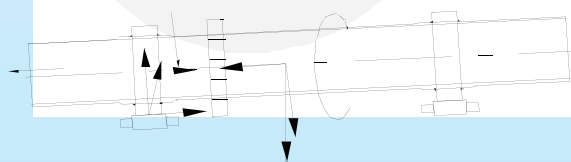

We can also support you with repair technology, preparation for the shell straightening by cutting and resetting, replacement / alignment of girth gear and tires, chair pad replacement, chairpad shimming and adjustment system of our own design

KILN SHELL OVALITY

Kiln shell ovality is an important parameter to assess kiln health and the monitoring become mandatory upon recurring refractory problem. Ovality, is defined as difference of shell diameter in horizontal and vertical axis. The difference arises because of flexing in kiln shell during operation, thermal, material loading, etc attributed for the difference.

Air gap

The shell flexing is governed by following factors:

1. beam strength of tyre
2. kiln shell thickness
3. kiln shell and tyre temperatures
4. kiln shell misalignment
5. air gap between tyre ID & chairpad OD
6. thermal and material loading
7. high run-out of kiln shell close to support stations, etc

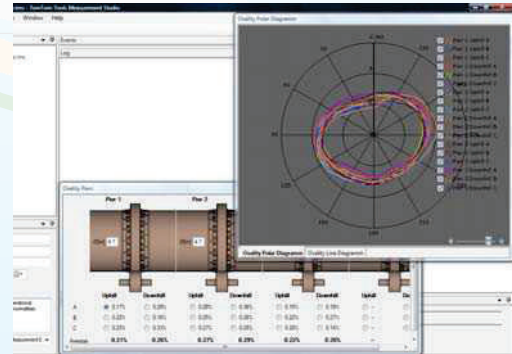

Variation in any of above factors influence shell ovality and has a detrimental effect upon the exceedance. Higher ovality has influence over refractory failure under / close by tyre section, undue stress on kiln shell and tyre section. If higher stresses are allowed for extended period, premature failure of refractory / mechanical element may results.

The measurement (services) is being carried out using high resolution beam, by directly mounting the sensor on shell during normal operation. The sensor measure and record the shell flexing using strain gauge (**instead of dial gauge**), during operation for the analysis. Manual / transfer error is eliminated by continuously transfer of collected data from the sensor directly to data logger (**laptop**) during the operation using blue tooth data transfer technology.

The graph generates represent behavior of a point on kiln shell during rotation. Typical graph appended below.

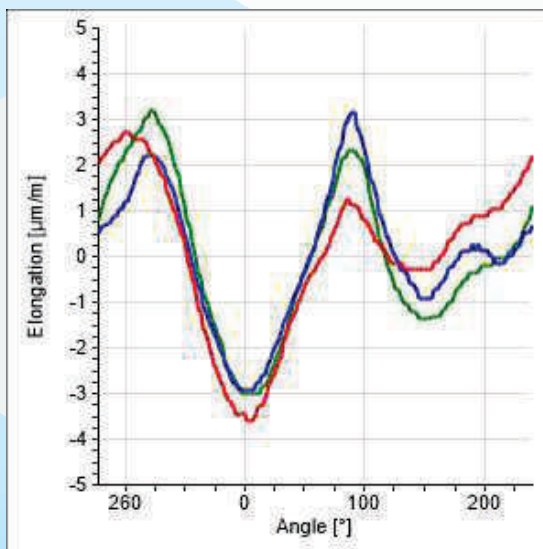

LINEAR GRAPH

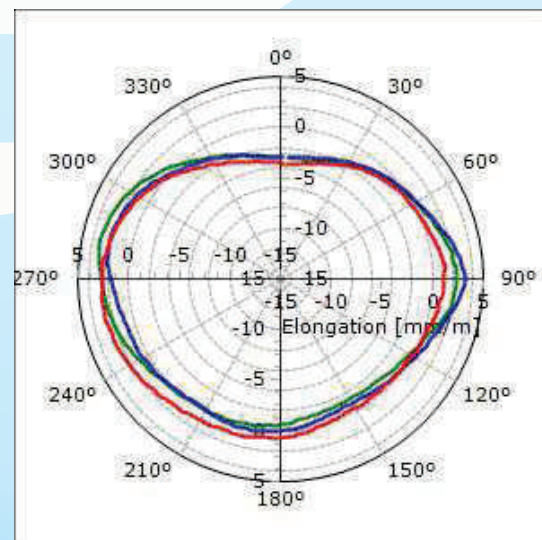

POLAR GRAPH



ROTARY DRUMS

ALIGNMENT ANALYSIS, INSPECTIONS OF THE CARRYING SYSTEMS AND SHELL GEOMETRY

ROTARY KILN'S SHELL STATE EVALUATION BY THE MEASUREMENT OF ROLLER SHAFTS' DYNAMIC DEFLECTION

Kiln shell's state, or shell's state of rotary drum with similar design, it used to be estimated with application of so-called measurements of geometry. These measurements consists in evaluation of shell's run-out in individual object's planes, located along kiln's length in adequate density. Thanks to this we can get maps of eccentricity and local deformation distribution, what is the base to make decision about remedial activities **/1/**.

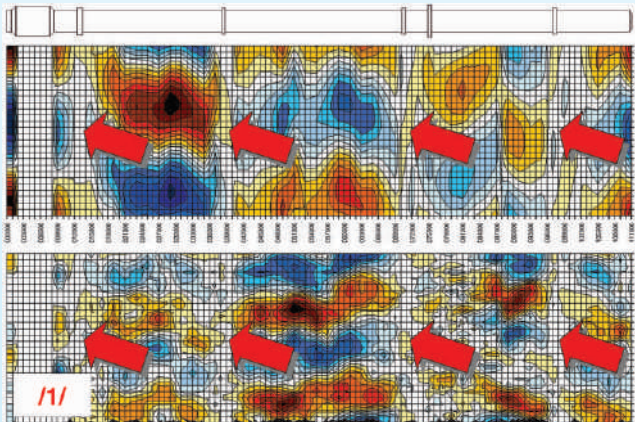

But these measurements have very essential mistake. Visual view of these maps shows us clearly, that in support places – in places of rings' mounting – vector of eccentricity is close to zero value and deformations are significantly reduced.

So it suggests a question: do deflections of shell's axis take places only between supports?
Answer is obvious: surely not.



/2/

Apparently, with relatively flexible shell, weight of ring is significant enough and stiffness of rollers considerably sufficient, that the shell is not capable to release itself from put on constraints.

Only in extreme cases, deflection of shell leads to "ring" jumps", what is displaying as loss of contact between it and rollers **/2/**.

"Rings' jumps" phenomenon occurs very seldom. Vector of eccentricity bigger than static deflection of shell in support point – for the case of removal of this support – creates the condition when phenomenon occurs, so it is the case, when we can detect eccentricity in the range of shell's support section **/3/**.

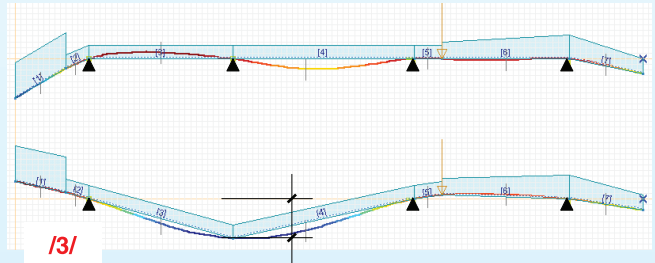

Static deflection very often achieves dozens of millimeters and even a few hundred (depending on shell's flexibility). From this reason "rings' jumps" are the rare phenomenon. But it doesn't mean, that, along with lack of shells run out in the range of support section, the problems can be omitted.

Shell's deflection causes cyclical changeable loads of rollers, thus creates cyclical changeable deflections of rollers' shafts. These deflections, distinct from static deflections coming from roller and kiln's nominal weight, are called dynamic deflections.

These deflections are main reason of material fatigue and, coming from it, roller shafts' cracking, what is the one of least desirable failures of the kiln **/4/**.



/4/

Moreover, invisible in the range of geometrical measurements, so-called hidden crank causes:

- increased stresses and shell deformation (ovalization) what has disadvantageous for strength and fatigue

- state (possibility of shell cracks) and it radically reduces durability of kiln lining;
- increased pressures between raceways of rollers and rings, leading to accelerated wear;
 - increased loads of roller bearings, what can be reason of high temperature and seizing;
 - foundation deflections causing scratches, cracks through and damages of continuous footing;
 - different failures unforeseen in effects, coming from sudden kiln's stoppage as a result of shafts' cracks (even bigger kiln deflection, destruction of drive system, destruction of outlet and inlet seal elements etc).

DynShaft device

Taking mentioned above factors into consideration, EUROKILN has designed and made device with working name **DynShaft**, serving for the measurement of roller shafts' dynamic deflection during normal operation of kiln **/5/**.



/5/

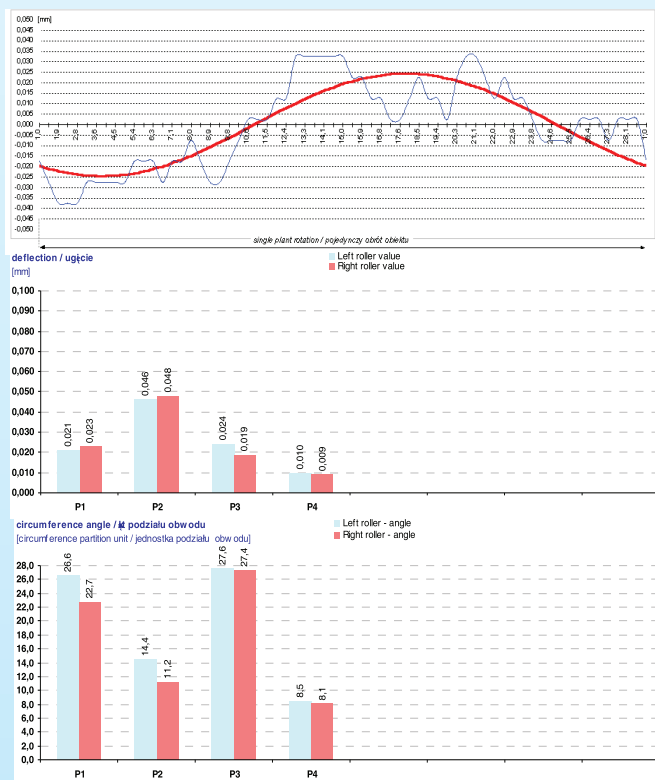

LT DynShaft device

Complex measurements of kiln shell's geometrical state are numbered among activities - very laborious and not every time economically justified, even when the shell axis state arouses suspicion.

From this reason, and also thinking about preventive requirements imposed on the kilns' users, EUROKILN firm worked out a simplified version of the device (Light) giving possibilities of periodical, independent control of roller shafts' deflection, to be done by the user **/6/**.

LT version device gives opportunity to estimate maximum shaft's deflection and informs about the circumference loca-



tion of kiln, where the extremum of deflection is situated. **LT** version has got also possibility of recording and future data reproducing. Moreover it is equipped with alert option informing if data is over permissible value, as well as it has got module to self-control of measurements.

For special order, it is possible to prepare the Interface for transmission, store and data analysis, dedicated to Windows system (for PC class computer).

It is possible also to include measurement of shafts deflection on the Internet diagnostic toll **Your Inspection OnLine** system, offered by EUROKILN company.

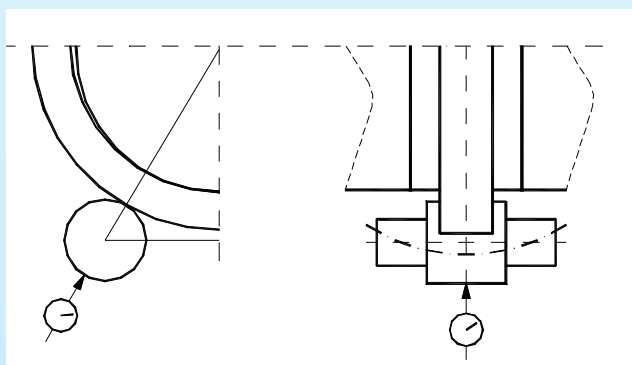

Main section parameters \
główne parametry przekroju :

Eccentricity / mimosrodość : **0.088 mm**
 Number of angle / number kata podziału obwodu : **16.07 N⁰**
 Max. deviation / maksymalne odchylenie : **0.920 mm**



ROTARY DRUMS

RESURFACING OF RINGS AND ROLLERS RACEWAYS BY GRINDING

INTRODUCTION

Main components of a rotary drum are rings and rollers, which are forming its support system.

The drum's working movement is rotation, additionally accompanied by axial displacements. Resistance of both movements is closely dependent on the contact conditions between the surfaces of rollers and rings. Correct contact between the two is guaranteed only when the raceways of both components are cylindrical in shape.

Unfortunately, even during normal operation, rotary drum is exposed to numerous factors, which in a long run will cause deformation of the contact surfaces, making the rolling components losing their original shape in a larger or smaller degree.

Such factors are:

- roller shafts misalignment /1/,
- ring axial run-out /2/.

They result in excessive and unevenly distributed loads on the contact surfaces of the ring and the rollers.

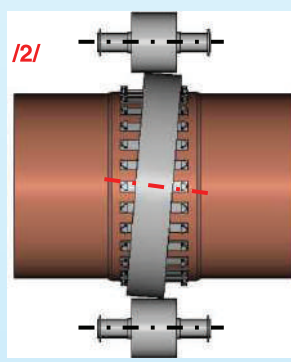
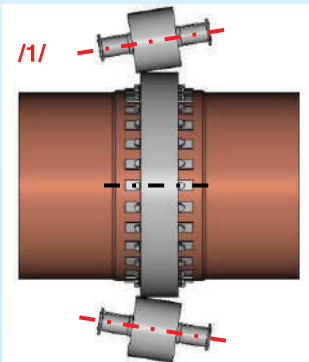

Complete elimination of the above-mentioned factors is difficult, and sometimes even impossible. Shape errors (/3/, /4/) are therefore inevitable, and their magnitude and rate of occurrence depends on the number and values of faults.

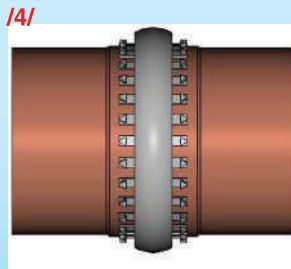
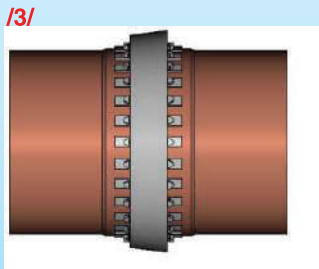

Errors, even the smallest, disturb the correct distribution of forces in the rotary drum's support system, forming points where the unit loads exceed the permissible values /5/.

In extreme cases such errors can cause serious disturbances in the drum's movements, both rotary and

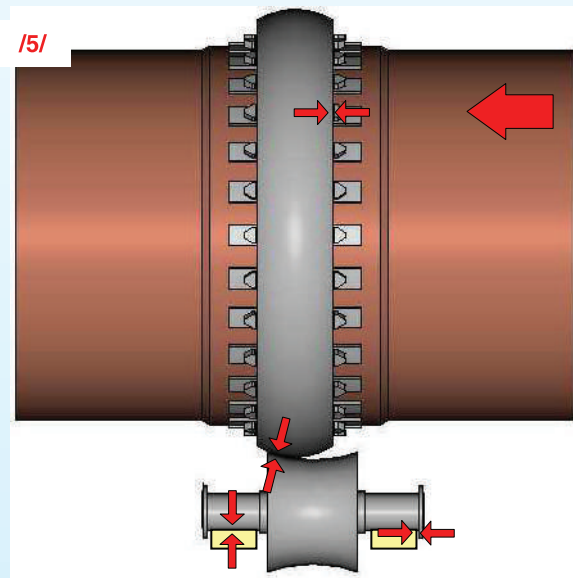

axial.

Movement resistance and incorrect distribution of forces can result in considerable damage, such as:

- wear, breaks of the thrust stop blocks /6/ ,
- bearing bushing damage by excessive loads /7/ ,
- breaks of the roller shafts' thrust collars,
- hastened wear of the rollers and rings raceways caused by increased unit loads in their contact areas /8/, /9/ .

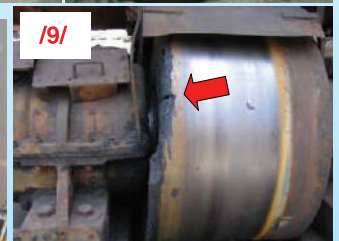
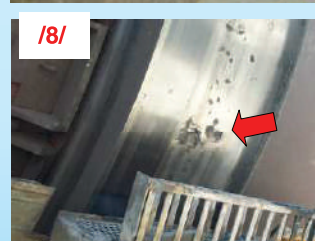
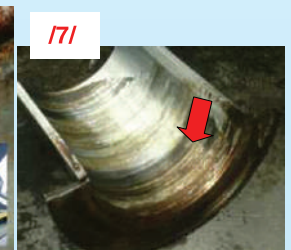
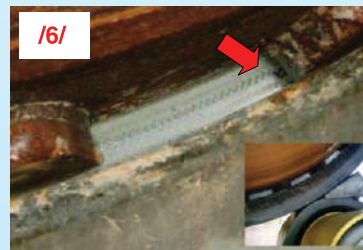

Such a movement resistance has also a negative effect on the drive system, where the teeth wear in the gear unit is following faster /10/. This creates a feedback which results in further deformation of the rings raceways, this time as characteristic furrows /11/.

Removal of such damage entails significant costs caused by both, production downtime and elimination process of the failure results.

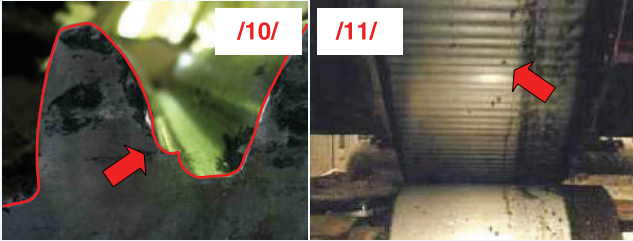

THRUST ROLLERS

Other important elements of rotary kiln support system are the thrust rollers. By taking part of the axial forces acting on the object's support system, they are often exposed to considerable loads. For this reason, it is very important to ensure the proper roller's positioning and raceway contact with the front surface of the live ring, so the forces distribution will be even and there will not be any formation of excessive stresses or vertical forces – over pressing or picking up the thrust roller on the frame. What in extreme case may lead to total failure of roller structure or damages of live rings' suspension system.

Periodical checks and restoration of the correct shape of live rings and support and thrust rollers raceways is desirable from the technical point of view and fully justified business-wise.

TRADITIONAL MACHINING

The shape can be restored in a traditional way: by dismantling and machining on stationary equipment. In such case, the downtime is inevitable: if the rollers are refurbished, the downtime will be shorter (a few dozens of hours); in case of the ring, the downtime will be fairly longer (several weeks).

The costs of restoration are also sizeable, and include amongst others:

- dismantling and re-assembly (in case of the ring, often the kiln's shell needs to be cut),
- transport (difficult, as the parts are usually over-size),
- machining (machine tools are few and expensive).

Machining without dismantling any parts of the facility, even during its normal operation can significantly reduce such costs.

In case of the support and thrust roller, which axis of rotation is relatively stable, for turning and grinding operations we can use more or less adapted traditional machines.

In case of rings raceway, continuous changing of the axis position necessitates much more sophisticated and refined technology, unavailable on a day-to-day basis.

The machining requires also a deep knowledge and an extensive experience in measurements and adjusting of such facilities.

NEW SOLUTION

The knowledge and experience which dispose ZMP engineers, together with the state of the art equipment, allow effectively resurface support and thus rollers and live rings raceways without the necessity of their dismantling.

Appearing always in case of the ring and sporadically in case of the support roller, displacements of the rotary axis of the machined element are compensated by the rotary joints which allow machine to follow-up to the right position.

Constancy of the diameter is assured by the proper design of the rolling guiding system. The idea of the solution is basing on the three points determination of the circle diameter. Constant holding down is provided by the pneumatic cylinder. Thanks to that machining parameters are constant what is very important for the obtaining good quality surface after grinding.

SCOPE OF SERVICE

Having in our disposal so specialized machines supported by our engineering knowledge of rotary drums related problems, we can offer you a complex service of support, thrust rollers and live rings raceways resurfacing.

The service contains:

- qualifying analysis, to determine advisability and possibility of resurfacing service;
- measurement and engineering assistance over the support roller's position adjustment;
- resurfacing of the support roller /12/ / live ring raceway /13/ with control of diameter and shape of the generating line of the grinded element;



resurfacing of the thrust roller – restoration of the initial generating line shape /14/ ;
resurfacing of live ring's front surface – in contact with thrust roller - restoration of the outline and/or cone's angle /15/ .



ADVANTAGES

no need for costly and time-consuming dismantling and re-assembly;
elimination of expensive transport to and from the machining facility;
minimizing the production losses (only in extreme situations resurfacing could disturb production process – necessity to decrease rotation speed of the drum in case of high vibration level of resurfacing elements);
during machining, the reference line is actual axis of rotation of the piece (high accuracy, minimal shape errors);
low surface roughness after regeneration,
low cost of service in relation to obtained result; (improvement in operation and increase of the durability and reliability of the object).

APPLICATION

grinding of the raceways of support rollers, live rings (tires) – rolling raceways and front surfaces and thrust rollers of rotary drums without dismantling;
grinding of other large rotary pieces, without dismantling (indispensable rotation of the resurfacing element).

**Find out how cheap it is!
Please contact us
and we will prepare a quotation for your object.**





ROTARY DRUMS

Graphite blocks

CONVENIENT LUBRICATION OF ROLLERS AND TIRES RACEWAYS

Selection of the right type of lubricant for the rolling elements is one of the most important problems which face the rotary drum maintenance staff. Oil based lubricants or even occasional use of water generates disadvantageous effects in the surface layers of race way's material. On the tire – see the photo below – are presented the effects of pitting phenomenon, depending on the chipping of the parts of material, which is subject to changeable pressure in presence of incompressible liquid. Micro cracks present on the tire (and/or roller) surface are filled up with the oil (or water) and those are compressed by the very high contact pressures, causing further defects propagation up to the form of wide material chipping.



Besides, it is not difficult to imagine wet (and/oiled) surface in dusty environment. It is not too esthetic view. Moreover connection of dirt, dust and other production process based substances, is not only disadvantageous appearance, but also a difficulties in maintenance and in even force distribution in supporting system. **Alternative to oil and water is graphite** .

This special form of carbon as a medium of lamellar hexagonal crystal structure and anisotropic properties, under the load of even low tangential stresses shows easy displacements of crystal layers. This property (called compressibility) is the base of use of graphite as the main or as a base component of the lubricant.

Additionally, use of graphite, which is a dry lubricating medium, enhances the cleanness of lubricated surfaces. Not without the matter are also the economical and the ecological aspects.

Besides the graphite there are other known chemical compounds of similar properties. In common use we can find also:

- boron nitride,
- borax,
- mica,
- molybdenum diselenide,
- molybdenum disulfide,
- wolfram disulfide.

Those compounds, although of similar properties, differ from each other with chosen parameters of which the most important is the coefficient of sliding friction. Also the graphite possesses a lot of additional-features, which determines or even excludes its use in specific conditions.

During the selection of the proper lubricating medium there should be considered:

- value of slope of the drum,
- rotary speed of the drum,
- unitary pressure in the spot of tire and roller contact,
- environment conditions (temperature, dustiness, ...),
- type of drum's drive.

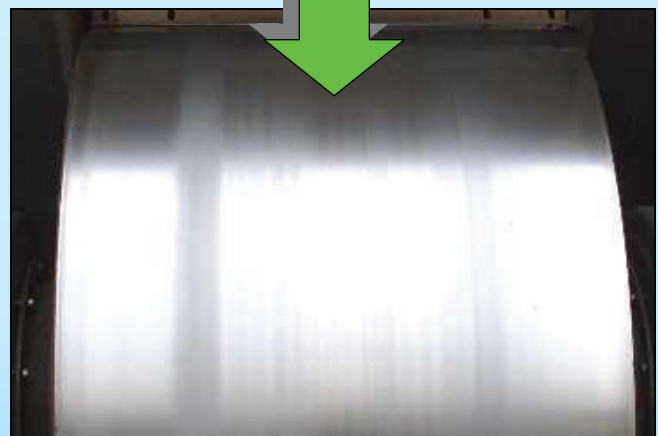
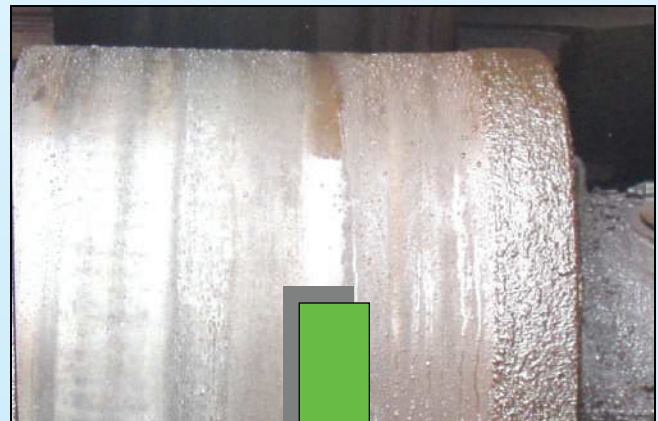

ROTARY DRUMS

Graphite lubrication system SOLUTION DEDICATED TO INDIVIDUAL REQUIREMENTS

Knowing the object's parameters and specific exploitation conditions, we can determine the type of lubricant – optimal for the analyzed application. In case of graphite based solution or similar medium indication – we will also design the right construction for product application.



To complement the implementation process, we offer manufacturing and assembly of complete system sets on the object.

Attention:

- implementation of the new raceway lubrication system changes the friction coefficient between the tire and rollers;
- such a situation requires calculation of the new target values of rollers' skews to compensate changes of axial forces, which are the effect of mentioned friction coefficient changes;
- in case of objects which are subject to our frequent audits, calculations are executed basing on the data obtained during the last inspection;

- in case of objects of transient state of support system geometry, necessary complementation of the service is detailed measurement of the object to determine actual skews of the rollers and axial forces distribution;
- in both cases we provide suitable assistance - supervision over the adjustment implementation of rollers skews, to obtain the expected final effect.

ADVANTAGES OF GRAPHITE LUBRICATION

- minimization of pitting and spalling effects,
- increase of object's axial stability (by the increase of friction coefficient stability),
- constancy of friction coefficient on the wide spectrum of temperature conditions,
- increase of raceways' cleanness (limitation of risk of raceway's damages in case of presence of unnecessary dirt on surface),
- easy and safe lubricant application,
- limited to minimum servicing activities,
- possibility to adapt the system for any type (construction) of rotary drum,
- low cost of using.

Appropriate position for fixing the graphite block

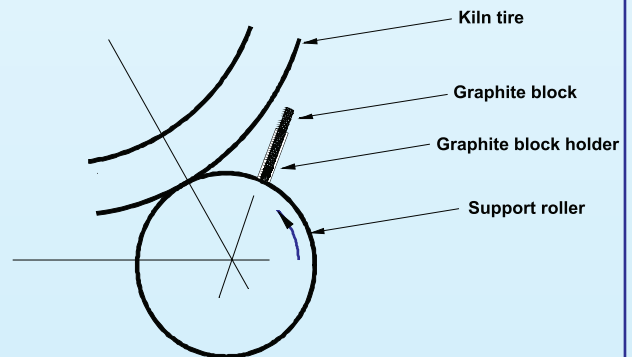

To avoid chattering of block, Line of action of graphite block should be off center



www.zmp.com.pl

ZAKŁAD MECHANIKI PRZEMYSŁOWEJ - ZMP S.C.

office address: ul. K.Fiedlera 6d 85-796 Bydgoszcz POLAND
phone /office/: +48 (052) 343 56 55, +48 (052) 360 60 56
fax /office/: + 48 (052) 360 60 55
mobile phones: 0 602 652 788, 0 697 055 475
e-mail: biuro@zmp.com.pl



DR SMART

Permanent Inspection of Your Rotary Kiln

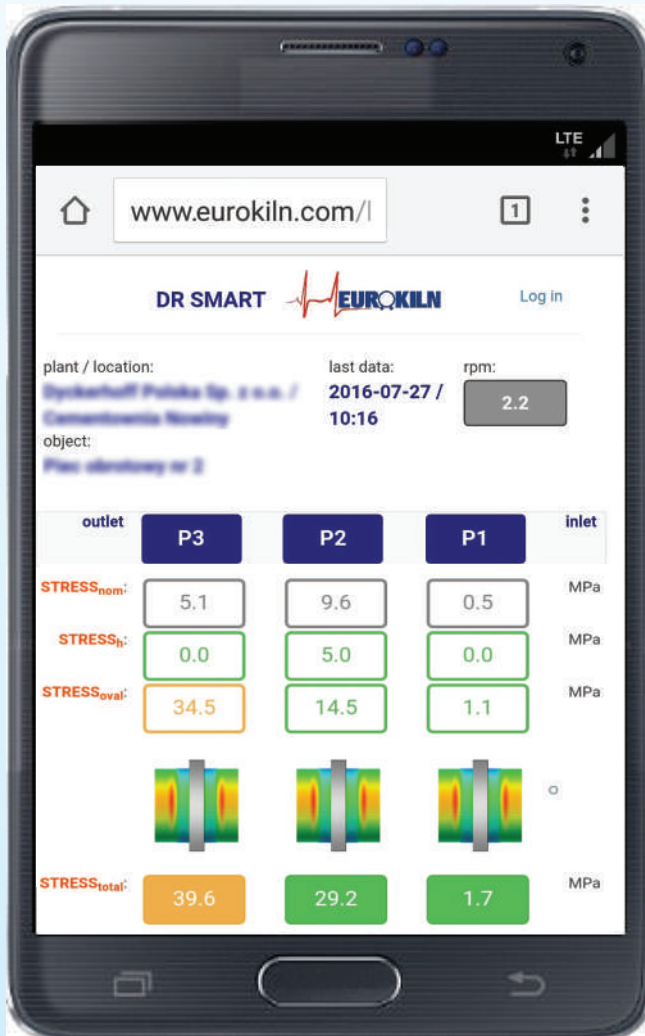

Basing on many years of experience in the field of rotary drum inspections - in particular of cement kilns, ZMP engineers have developed a system of permanent supervision of key parameters of this type of objects.

The main assumptions for the system were: simplicity of system operation on the user's side as well as innovation and advancement of the analytical and diagnostic tools implemented in it, operating in the background, completely independent of the will of the user.

As a result, a product was created, including software that is adapted for use on smartphones, thanks to which the user is immediately informed (via SMS message) about significant irregularities and / or anomalies in the mechanical conditions of the rotary drum, and after starting the mobile application user can view selected details, however, limited to only highly processed and valuable information, so that he can take an immediate and reliable reaction.

the genesis of the idea

Periodical inspections of rotary drums in order to assess their mechanical condition are performed with consistency dependant on the importance of role that these objects are taking in the production chain and depending on the pace of anticipated wear of their components, but usually not more often than every few months, and in some extreme cases - even only every few years. Such a frequency gives the opportunity to assess the condition of an object at a precisely defined point on the time axis and for strictly defined operating conditions. However, it does not give the possibility of continuous evaluation, considering the changes of production conditions. Therefore, it also does not give, what is equally important, the possibility of unequivocally genesis the causes and the moment of occurrence of potential damages.

This limitation in the inference back, i.e. the inability to capture a specific point in time, in which the given defect was initiated, is a basic drawback of periodic diagnostics, carried out sporadically and constitutes a significant disadvantage in relation to continuous monitoring.

A kind of a substitute for continuous mechanical monitoring of rotary drum condition are, more and more often used on rotary kilns systems for scanning the shell temperature, or systems used for continuous measurement of migration of live rings. In the first case, however, we do not get any valuable feedback on the influence of the observed temperature distribution of the shell on the operation of the key mechanical elements of the kiln. We do not know what value reaches the crank of the geometric axis of the kiln coming from the temperature disturbances and what consequences it results in terms of both the load on the shell and the load on the components of the support system (live rings, support rollers). We also do not have the view of the impact of possible uneven temperature distribution on the perimeter of the shell on the load of the drive section components. Their effectiveness is therefore limited to the assessment of the internal lining condition and indirect assessment of the quality of the production process.

In the case of migration measurement - very often it is not related to the difference between the temperature of the shell and the temperature of the live ring. Stresses in the material of the shell are also not calculated, i.e. effects associated with excessive migration (excessive under ring clearance - ovalization) or lack of migration (interference). Such a measuring system records only the lack of clearance (interference), but it does not inform the user what kind of stresses the pressure causes. It is also known that in the case of ring jam on the shell the stress in the material of the shell usually exceeds the value of few hundreds of MPa and cause immediate and permanent deformation, or even degradation, in this they are one of the additional sources of damage to the internal lining.

This gives the market view on which we have a choice or the possibility of using very advanced and comprehensive methods for mechanical evaluation of the drum condition, which due to high costs are realized only individually and by specialized companies - in a strictly defined period, or relatively basic information systems - monitoring only selected, basic parameters of the object, mainly those related

to the production process, less often those related to the area of mechanics, in addition without analysis of their mutual relationship.

This gap and competences of ZMP became a catalyst for the development of a system that combines the principle of continuous monitoring of selected parameters of the object with their simultaneous processing for the information relevant to the mechanics, and thus from the point of view of strength of individual components of the machine where the obtained values, especially stresses, unambiguously compare with the limit values - acceptable for the used material.

construction and operating principle of the system

The system is built of modules :

- control unit (quantity = 1), which supervises the rotational speed of the object, initiates measurements in the remaining modules, controls the correct operation of these modules, collects data from all modules and sends them to the data server (to ZMP),
- measuring type PIER (quantity = number of supports of the drum), which collects "on request" of the control module data from sensors located on a given support, where as standard supervised are:
 - circumferential migration of the ring in relation to the shell (indirectly under ring clearance),
 - dynamic deflection of support rollers shafts (indirectly so-called hidden component of shell geometrical axis),
 - axial run out of live ring (indirectly its wobbling and axial expansion of the kiln shell),
 - axial positions of support rollers (indirectly directions of axial impact of the support rollers on the object),
 - shell temperature (average value and circumferential distribution),
 - temperature of live ring,
 - temperatures of support rollers bearings (by direct or indirect measurement),
- measuring type GR (quantity = 1), which collects "on-request" from the control module, data from sensors located on the drive section, where as standard supervised are:
 - radial run out of the gear rim (indirectly the variability of the meshing clearance with the pinion),
 - axial run out of the gear rim (indirectly its wobbling and axial position in relation to the pinion),
 - vibrations of selected bearings (values like: RMS and peak and selected harmonic components).

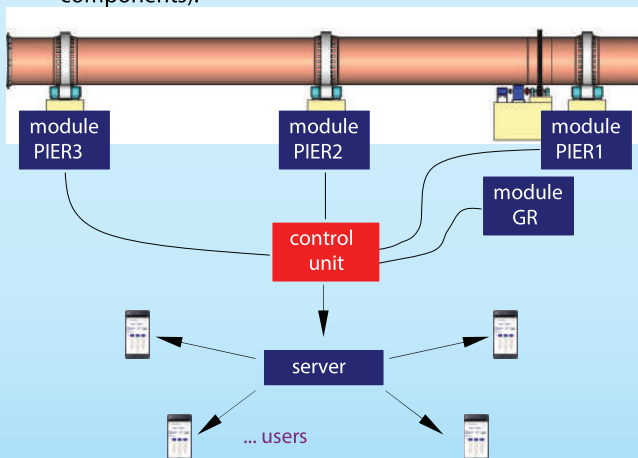

Data (measured by the measuring modules) are transferred and collected in the control unit. There, a software with sophisticated analytical algorithms makes them further processed and as a result, we get:

- stresses in the shell coming from so-called „hidden crank component“ of shell geometrical axis,
- stresses in the shell coming from ovalization, dependent on the under ring clearance,
- total stresses (summarized) in the shell on individual supports, which are a composite of the above stresses and stresses originating from the bending of the shell axis (from the geometrical shape of the axis of the support system).

These stresses are compared on a regular basis with the permissible values for the used shell material and in case of exceeding these limits, the system generates relevant messages .

The system also calculates :

- under ring clearance, and in the case of a lack of clearance, estimates the pressure and stress value associated with this interference,
- dynamic deflections of support rollers shafts,
- crank value of shell geometrical axis (hidden component of eccentricity) and the values of forces from additional loads generated by this crank,
- wobbling of the live rings and gear rim .

The values of these parameters are also compared to the permissible values, where they are calculated mainly from strength dependencies.

Limit values and general principles adopted for their determination are given in the User's Manual (provided with the system), and the details of the system and its components as well as the analytical application are presented as part of the training accompanying the system implementation process for a given facility.

types of messages

The system is equipped with two mutually complementary ways of notifying the user about the occurrence of exceeding the limit values:

- SMS messages ,
- graphic messages generated in the application (directly on your smartphone).

SMS messages are sent to a strictly declared group of users (persons indicated as interested in the condition of the kiln), and the system distinguishes between two types of notifications:

- warning level - this is information about exceeding the warning level by any supervised parameter; this information is sent not more often than every 24 hours - regardless of the number of parameters, for which the exceedance occurred (in the standard setting),
- alert level - this is information about exceeding the critical level by any supervised parameter; this information is sent not more often than every 6 hours - regardless of the number of parameters for which the exceedance occurred (standard setting)

!!! Alert !!!
 2016-08-11 (09:16)
 Cement Plant ... / Kiln ...
 Go to: <http://www.online.eurokiln.com>

Graphic messages are designed to make it easier for users to see in the application (on the smartphone) the parameters and moments in time when these exceedances occurred.

Thanks to the link placed directly in the SMS message, you can quickly go to a mobile application which, after user identification, gives the possibility of a more detailed view of the numerical values of all key, supervised and calculated parameters, including viewing their limits.

The supervised values (measured - calculated) are arranged in columns corresponding to the subsequent supports of the kiln and are placed in colored frames, where the background and frame color mean respectively:

- white background / green frame – no objections to the current value of a given parameter ;
- white background / orange frame – exceeding the level of warning alert for the current value of a given parameter;
- white background / red frame – exceeding the level of critical alert for the current value of a given parameter.

In the case of summary (total) stresses calculated for the shell, due to the superior importance of this factor, in addition to changing the color of the frame, the background color also changes .

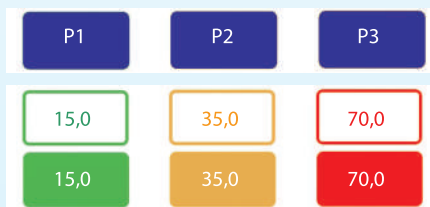

After clicking on a given frame with a numerical value of any parameter, the user has the opportunity to review historical data in the form of daily, monthly or yearly charts, in all cases against the background of limit values.

The speed curve is also displayed on each graph (gray line at the top).

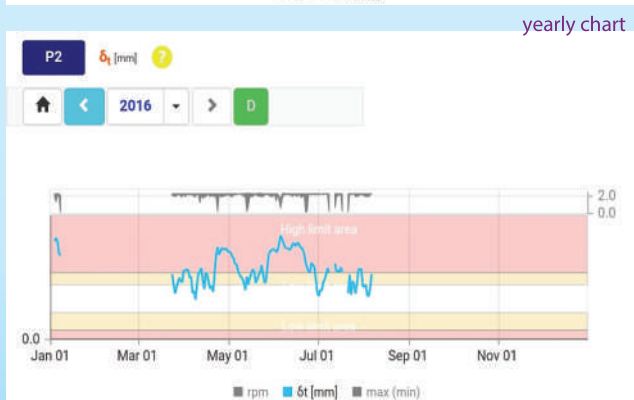
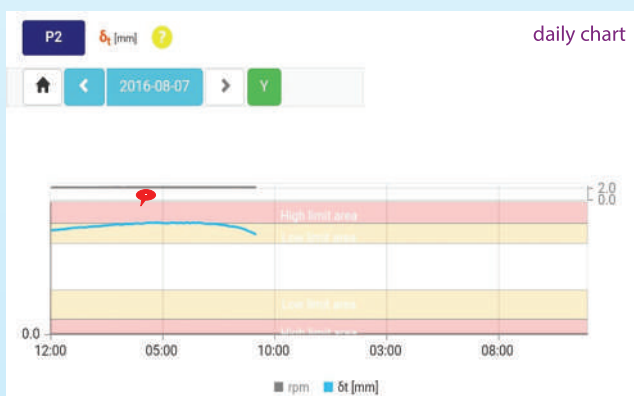

Charts on a daily basis are enriched with additional symbols - message bubbles indicating the moment the system generates (sends) an SMS message (low or high level).



The user, by changing the system settings, but only on his individual user profile, has the option to stop the emission of SMS messages, declaring such a need for a maximum period of 30 days. This fact is noted by the system software and then graphic messages - the balloons on the charts turn gray. It gives the information about an alert but without an SMS - at the explicit request of a given user. Such a situation is provided, for example, for the fact that the system informs about a well-known problem, but the user of the object has accepted it.

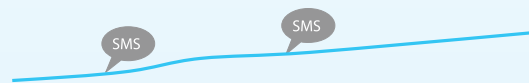

system benefits, advantages of implementation

- ✓ immediate information about the risk of damage to individual components of the supervised object;
- ✓ access to data showing the current mechanical condition of the kiln from anywhere in the world, using a smartphone or any other device equipped with a web browser;
- ✓ data security thanks to identification of individual users and their profile settings ;
- ✓ simplicity of application and legibility of displayed information on the user's side;
- ✓ automation of measurements and their integration with sophisticated analytical methods, including strength calculations (currently the most advanced and specialized system for diagnostics of multi-support rotary drums from the point of view of their mechanics) ;
- ✓ elimination of the costs of maintaining your own specialized diagnostics team and reducing the costs of hiring specialized external companies while ensuring continuous and substantive monitoring of the facility ;
- ✓ relatively low implementation and maintenance costs, with the option of system implementation in several stages ;
- ✓ the possibility of rational management of spare parts and consumables, as a result of observing trends of individual parameters of the drum, affecting the durability of its components ;
- ✓ a fuller understanding of the pace and causes of degradation processes (wear, disregulation of the system, etc.);
- ✓ a fuller understanding of the relationship between individual object parameters and its mechanical state (correlation trend analysis).

utilization

- large-size, multi-support (number of live rings three and more) rotary kilns (typical application);
- other rotary drums, including 2-support objects (solution requiring individual selection of the range of monitored and calculated parameters);

implementation stages

- comprehensive audit of the facility in the scope of the support system, shell and drive section, including the implementation of the necessary basic strength analyzes, to:
 - determine the object state,
 - set the strength limits for its individual components,
 - determine suggested adjustment and / or repair actions suggested to implement before the installation of the system,
- preparation and submission of a final price offer for agreed technical conditions of system implementation;
- implementation of the system including:
 - installation and calibration of measuring sensors,
 - adaptation of software for the needs of a given facility,
 - startup of the system,
 - training of the Clients personnel in scope of:
 - using the system, interpreting the results,
 - correctly operate and maintain the system,
 - annual service and substantive support (to the extent agreed in the contract);;
- post-warranty service (on terms agreed in the contract).

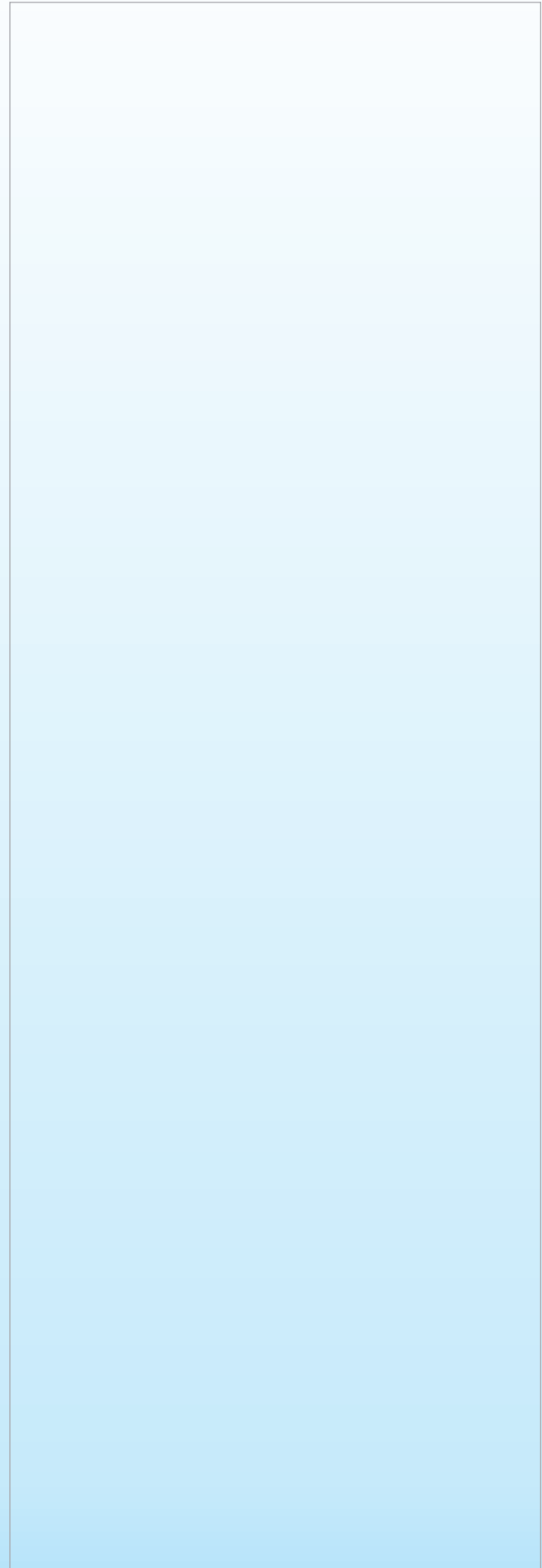

More information about company activities can be found on our Internet website www.zmp.com.pl .



Auxiliary table

" Damage, defect / symptoms >> proposed audit "

Symptoms ↓ Damage, defect	increased temperature of the roller bearings		cracks		excessive wear					loose lining (loose bricks)		vibration		gaps on the contact between the rollers and the rings	unstable axial displacement of the facility	increased current consumption by the drive	Proposed audit symbol ↓		
	on journals	on thrust collars	of the shell	of the roller shafts	of the roller and ring raceway	of the stop blocks (positioning the rings axially)	of the under-ring blocks	of the thrust roller	of the drive gear teeth	between the rings	under the rings	on the drive	on the rollers						
support system's shape axis error	+	/1		+	/1	+	/1										+	/1	A (T) lub A+
incorrect skewness of the rollers	+		+				+		+								+	+	A (A-11, T) or A+ (T)
elastic ovality of the shell, excessive under-ring clearance			+			+		+											A, B.7 (T)
bending of the shell axis	+	/1		+	/1	+	/1					+					+		B++ (T) B+ (T) or B (T)
axial runout of the rings	+					+		+									+	+	B+ (T) or B (T)
incorrect lubrication	+					+		+											individual selection
corrosion			+																E.1 (T)
lining quality										+		+							B.7 (T)
incorrect alignment of the drive section components									+								+		D.1 (T)
damage of the drive section components									+										C.1 (T) &/or D.2 (T)
raceway and/or rings shape errors						+											+		A.12.
incorrect position of the thrust roller									+										D.3.

/1 - the assignment of the symptom to the defect (damage) does not apply to a two-stage facility (applicable only to a multi-stage drum);

NOTE

Use this table to customize the scope of services by assigning the identified defects (damage) to the entries in the "Proposed audit" column. However, we recommend taking the advice of our expert, who will propose the audit fee free of charge, depending on the needs determined on a case-by-case basis, taking into account the economic conditions.

OUR ASSETS

A. EQUIPMENTS

1. Alignment Set:

- a. Hot Kiln Alignment 2 set

*Each comprises ROBOTIC Total Station, precision auto level
Most of measuring instruments are sourced from Switzerland
And measuring gadgets from Germany and Poland.*

- b. Cold Alignment 1 set

2. Grinding Machines:

- a. Tyre & Support Roller Grinding Machine 4 set
b. Tyre Thrust Face & Thrust Roller Grinding Machine 2 set
c. Slide Ring (Cement Mill Tyre Grinding Machine) 1 No.
d. Pneumatic Grinding Machine 1 No.

B. WAREHOUSE

- a. Unit No. 207, Building No. B/6, Bhumi World Industrial Park,
Tal. Bhiwandi, Dist. Thane, Pin Code - 421302

C. WORKSHOP

- a. Gala no. 1, Ground Floor, Building C/2, Arham Logiparc,
Vashind Village, Dist Thane, Pin Code - 421302

D. ALLAN SMITH TEAM

Our core strength is our team

- comprises 25 specialist including field experts and administrative team



ALLAN SMITH ENGINEERING PVT. LTD.

WHERE EXCELLENCE IS SECOND NATURE

Reg. Off.: Unit No. 612-B Wing, Lodha Supremus, Kolshet Road, Thane (West), Maharashtra 400 607, India.

L: +91 22 4962 2221

M: +91 90046 76484 / 98675 89351

E: admin@smithengg.in, ase@eurokiln.com

Website: www.smithengg.in | www.eurokiln.com | www.kiln.co.in



DUNS NO.: 864349051

More information about our firm's activity can be found on our Internet site www.eurokiln.com

